

geoquip

WATER SOLUTIONS

 **E-Tech**

ED/EDV - EGN - EGT/EGF SERIES 50 Hz

DRAINAGE PUMPS



INDEX

ED/EDV - STAINLESS STEEL DRAINAGE SUBMERSIBLE PUMPS FOR DIRTY WATER	2
Materials table	3
Dimensions and weights.....	3
ED - Table of hydraulic performance and performance curves.....	4
EDV - Table of hydraulic performance and performance curves	5
Installation examples.....	6
Features.....	7
EGN - SUBMERSIBLE DRAINAGE PUMPS FOR CLEAN WATER.....	8
Materials table	9
Dimensions and weights.....	9
Installation.....	9
EGN - Table of hydraulic performance and performance curves	10
Features.....	11
EGT/EGF - SUBMERSIBLE DRAINAGE PUMP FOR DIRTY WATER.....	12
Materials table	13
Dimensions and weights.....	13
EGT/EGF - Table of hydraulic performance and performance curves	14
Installation examples and dimensions	15
Features.....	16

NOTE: Franklin Electric S.r.l. reserves the right to amend specification without prior notice

For the most up-to-date product information, visit franklinwater.eu.

ED/EDV – STAINLESS STEEL DRAINAGE SUBMERSIBLE PUMPS FOR DIRTY WATER

CONSTRUCTION

- Single-impeller submersible pumps in chrome-nickel stainless steel, with vertical delivery port
- **ED:** with double channel impeller
- **EDV:** with free-flow (vortex) impeller
- Double shaft seal with interposed oil chamber

APPLICATIONS

- For clean and dirty water, also containing solids up to 35 mm grain size
- The EDV free-flow impeller construction is particularly suitable for liquids with a high solid content or with filamentous particles
- This construction (with smooth surfaces in rolled-stainless steel and easy access for cleaning) is also suitable for specific use in the food industry

OPERATING CONDITIONS

- Liquid temperature up to 35 °C
- Maximum immersion depth: 5 m
- Minimum immersion depth: 248 mm
- Continuous duty (with submerged motor)

MOTOR SPECIFICATION

- 2-pole induction motor, 50 Hz ($n \approx 2900$ rpm)
- **ED, EDV:** Single-phase 230 V $\pm 10\%$, with float switch and thermal protector
Incorporated capacitor
Cable: H07Rn-F, 3G1 mm², length 10 m, with plug Cel-UneL 47166; 5 m for ED5/EDV5
- **EDT, EDVT:** Three-phase 230 V $\pm 10\%$; Three-phase 400 V $\pm 10\%$
Cable: H07Rn-F, 4G1 mm², length 10 m, without plug; 5 m for ED5T/EDV5T
- Insulation class F
- Protection IPX8 (for continuous immersion)
- Triple impregnation humidity-proof dry winding
- Constructed in accordance with: EN 60034-1; EN 60335-1, EN 60335-2-41

AVAILABLE ON REQUEST

- Other voltages
- Frequency 60 Hz
- Other mechanical seal
- Cable length 20 m
- Motor suitable for operation with frequency converter
- Three-phase pumps with incorporated float switch

PUMP IDENTIFICATION CODE

ED V 7 T 400 50

- Motor frequency
- Motor voltage
- Three phase version (empty for single phase)
- Nominal power
- Free-flow impeller (vortex)
- Pump model



ED/EDV

MATERIALS TABLE

Components	Materials
Pump casing	Chrome-nickel steel 1.4301 EN 10088 (AISI 304)
Impeller	Chrome-nickel steel 1.4301 EN 10088 (AISI 304)
Motor jacket	Chrome-nickel steel 1.4301 EN 10088 (AISI 304)
Jacket cover	Chrome-nickel steel 1.4301 EN 10088 (AISI 304)
Casing cover	Chrome-nickel steel 1.4301 EN 10088 (AISI 304)
Handle	Polypropylene (with frame in AISI 304)
Shaft	Chrome-nickel steel 1.4301 EN 10088 (AISI 304)
Mechanical seal upper	Ceramic alumina / Carbon / NBR
Mechanical seal lower	Ceramic alumina / Carbon / NBR
Seal lubrication oil	Oil for food/pharmaceutical machinery

DIMENSIONS AND WEIGHTS

Pump model	Dimensions [mm]			Weight [kg]	
	fM	h max	h min	1 -	3 -
ED5(T)	433	508	248	12	10.3
ED9(T)	458	533	273	14	12.5
EDV5(T)	433	508	248	12	10.3
EDV7(T)	458	533	273	14	12.5
EDV9(T)	458	533	273	14	12.5

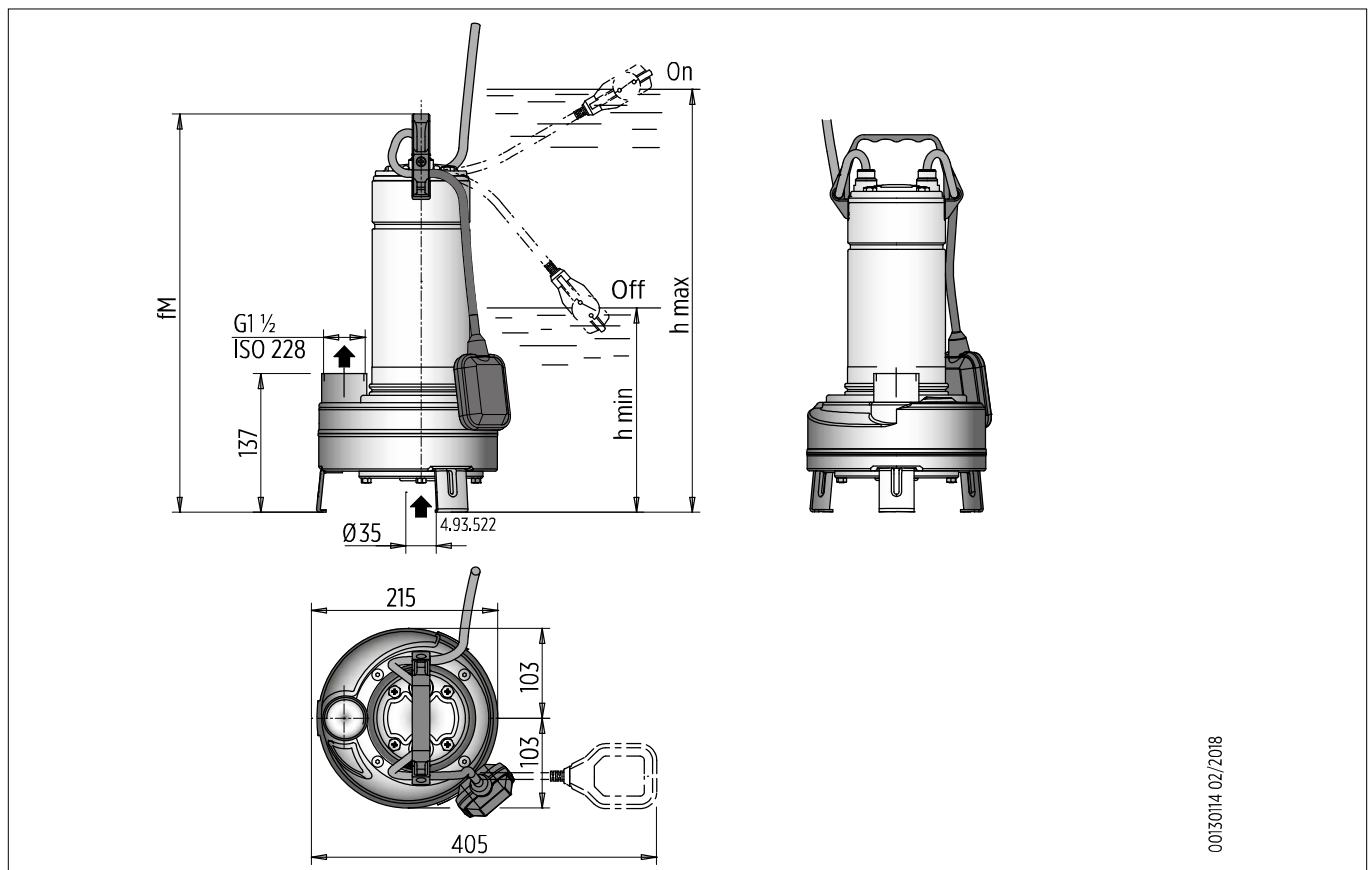

00130114_02/2018

ED

TABLE OF HYDRAULIC PERFORMANCE $n \approx 2900$ 1/min

Pump model	1x230 V			Capacitor		P ₂		Q = DELIVERY							
	[A]	[µf]	[Vc]	[kW]	[HP]	l/min	50	100	150	200	250	300	350	400	433
						0	3	6	9	12	15	18	21	24	26
ED 5	4.6	16	450	0.55	0.75	10.4	9	8	7.1	6.3	5.4	4.4	3.2	-	-
ED 9	6.6	25	450	0.9	1.2	12.9	11.6	10.5	9.5	8.7	7.8	6.9	5.9	4.7	4

Pump model	3x230 V		3x400 V		P ₂		Q = DELIVERY							
	[A]	[A]	[kW]	[HP]	l/min	50	100	150	200	250	300	350	400	433
					0	3	6	9	12	15	18	21	24	26
ED 5 T	2.8	1.6	0.55	0.75	10.4	9	8	7.1	6.3	5.4	4.4	3.2	-	-
ED 9 T	4	2.3	0.9	1.2	12.9	11.6	10.5	9.5	8.7	7.8	6.9	5.9	4.7	4

P₁: Max absorbed power

P₂: Motor nominal power

Density $\rho = 1000$ Kg/m³

Viscosity kinematic $\nu = \max 20$ mm²/sec

PERFORMANCE CURVES $n \approx 2900$ rpm

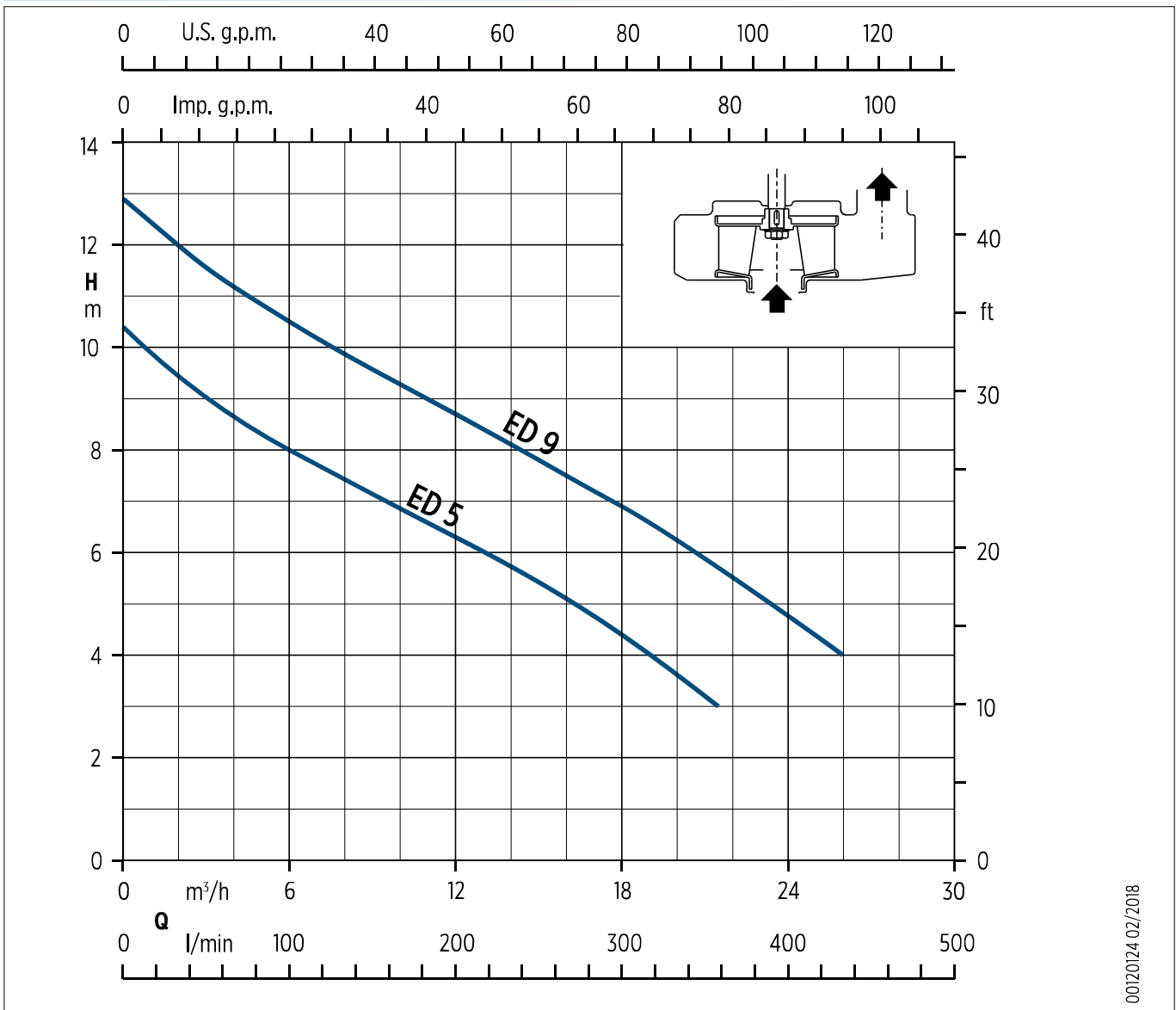

00120124 02/2018

EDV

TABLE OF HYDRAULIC PERFORMANCE $n \approx 2900$ 1/min

Pump model	1x230 V			Capacitor		P ₂		Q = DELIVERY							
	[A]	[µf]	[Vc]	[kW]	[HP]	l/min	50	100	150	200	250	300	350	400	433
						m ³ /h	3	6	9	12	15	18	21	24	26
EDV 5	4.6	16	450	0.55	0.75	7	6.2	5.4	4.6	3.7	3	-	-	-	-
EDV 7	5.4	25	450	0.75	1	8	7.2	6.4	5.5	4.6	3.7	2.8	-	-	-
EDV 9	6	25	450	0.9	1.2	9	8.1	7.2	6.3	5.4	4.5	3.5	2.4	-	-

Pump model	3x230 V		3x400 V		P ₂		Q = DELIVERY							
	[A]	[A]	[kW]	[HP]	l/min	50	100	150	200	250	300	350	400	433
					m ³ /h	3	6	9	12	15	18	21	24	26
EDV 5 T	2.8	1.6	0.55	0.75	7	6.2	5.4	4.6	3.7	3	-	-	-	-
EDV 7 T	3.8	2.2	0.75	1	8	7.2	6.4	5.5	4.6	3.7	2.8	-	-	-
EDV 9 T	4	2.3	0.9	1.2	9	8.1	7.2	6.3	5.4	4.5	3.5	2.4	-	-

P₁: Max absorbed power

P₂: Motor nominal power

Density $\rho = 1000$ Kg/m³

Viscosity kinematic $\nu = \text{max } 20$ mm²/sec

PERFORMANCE CURVES $n \approx 2900$ rpm

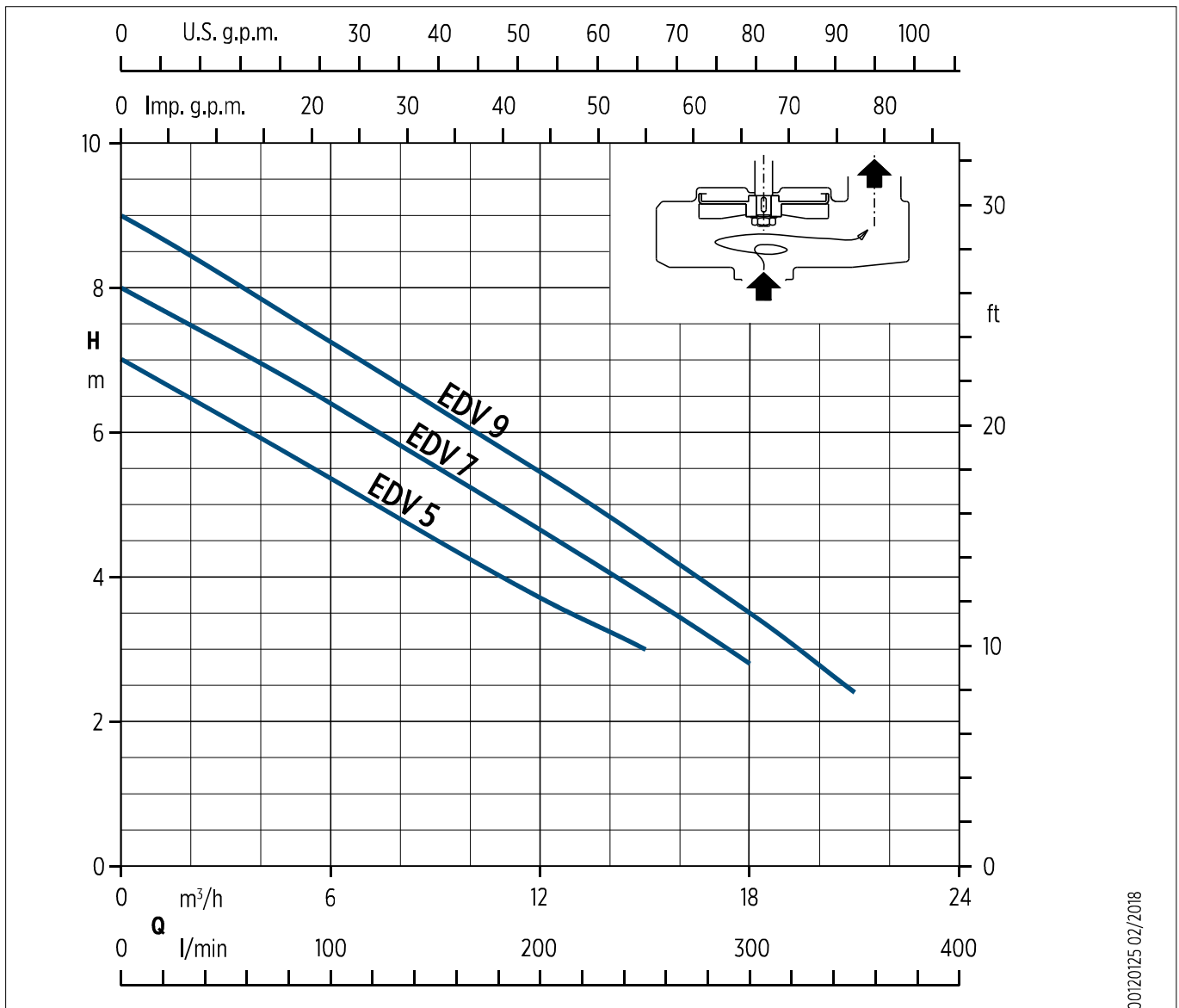

00120125 02/2018

ED/EDV - INSTALLATION EXAMPLES

STATIONARY INSTALLATION

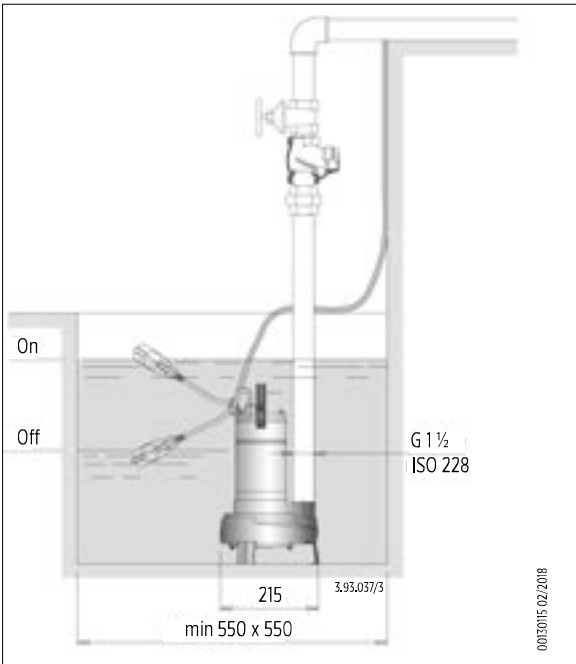

TRANSPORTABLE INSTALLATION

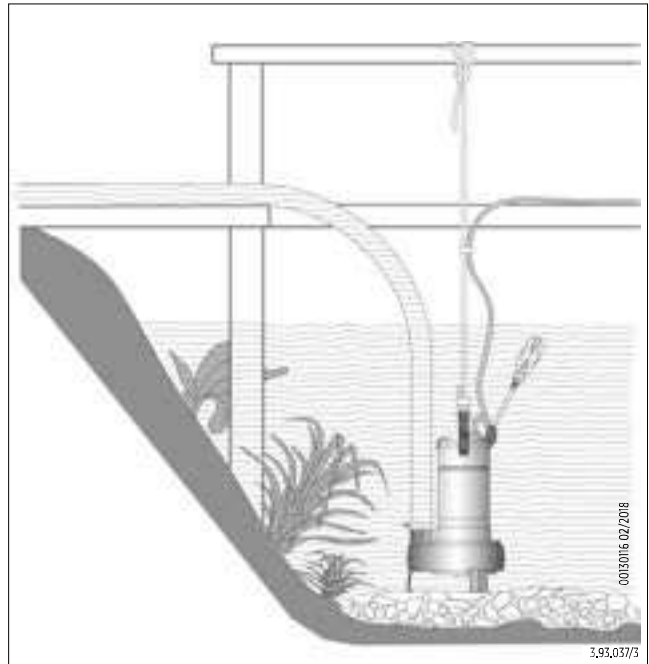

CONNECTION EXAMPLES

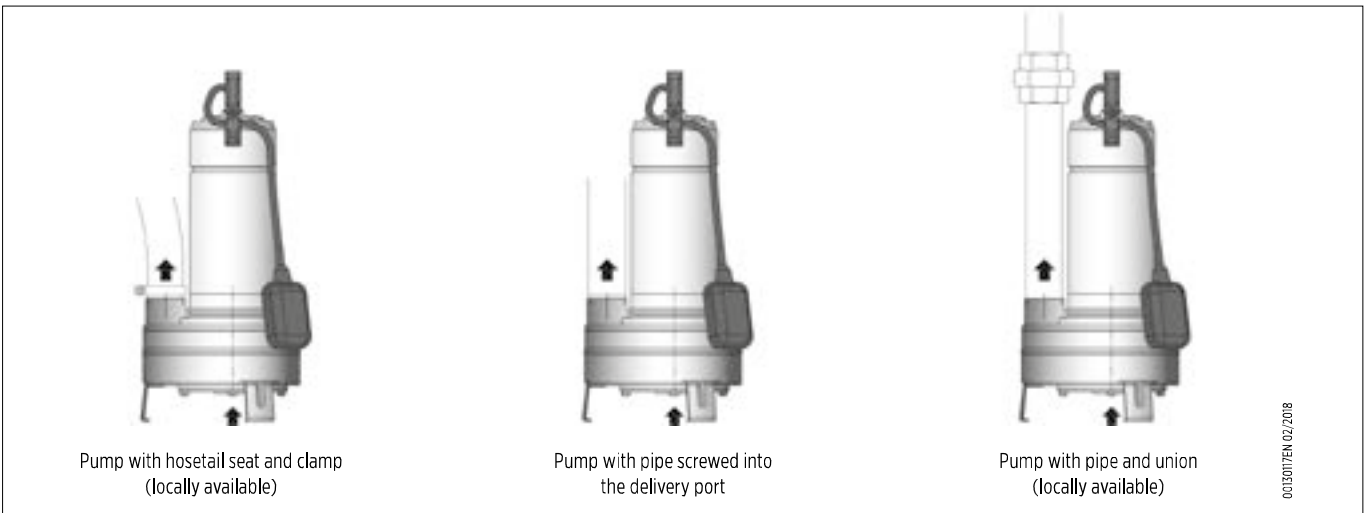

ED/EDV - FEATURES

Power cable with plug on single-phase pumps

Handle in polypropylene, with frame in stainless steel

Easy inspection of the capacitor area

Easy adjustment of the float switch: to allow the adjustment of start/stop pump levels

Ring against accidental extraction of the cable

G 1 ½ vertical, upward delivery port for installation in small pits, without the need for an elbow on the pump

The double shaft seal with oil chamber separates the motor from the water and provides further protection against accidental operation when dry

Totally in stainless steel all parts in contact with the pumped liquid both internal and external are in stainless steel AISI 304

Shaft in chrome-nickel stainless steel

ED the two-passage impeller construction is particularly suitable for liquids containing solids up to 35 mm grain size

EDV the free-flow impeller (vortex) construction is particularly suitable for liquids with a high solid content up to 35 mm grain size or with filamentous particles

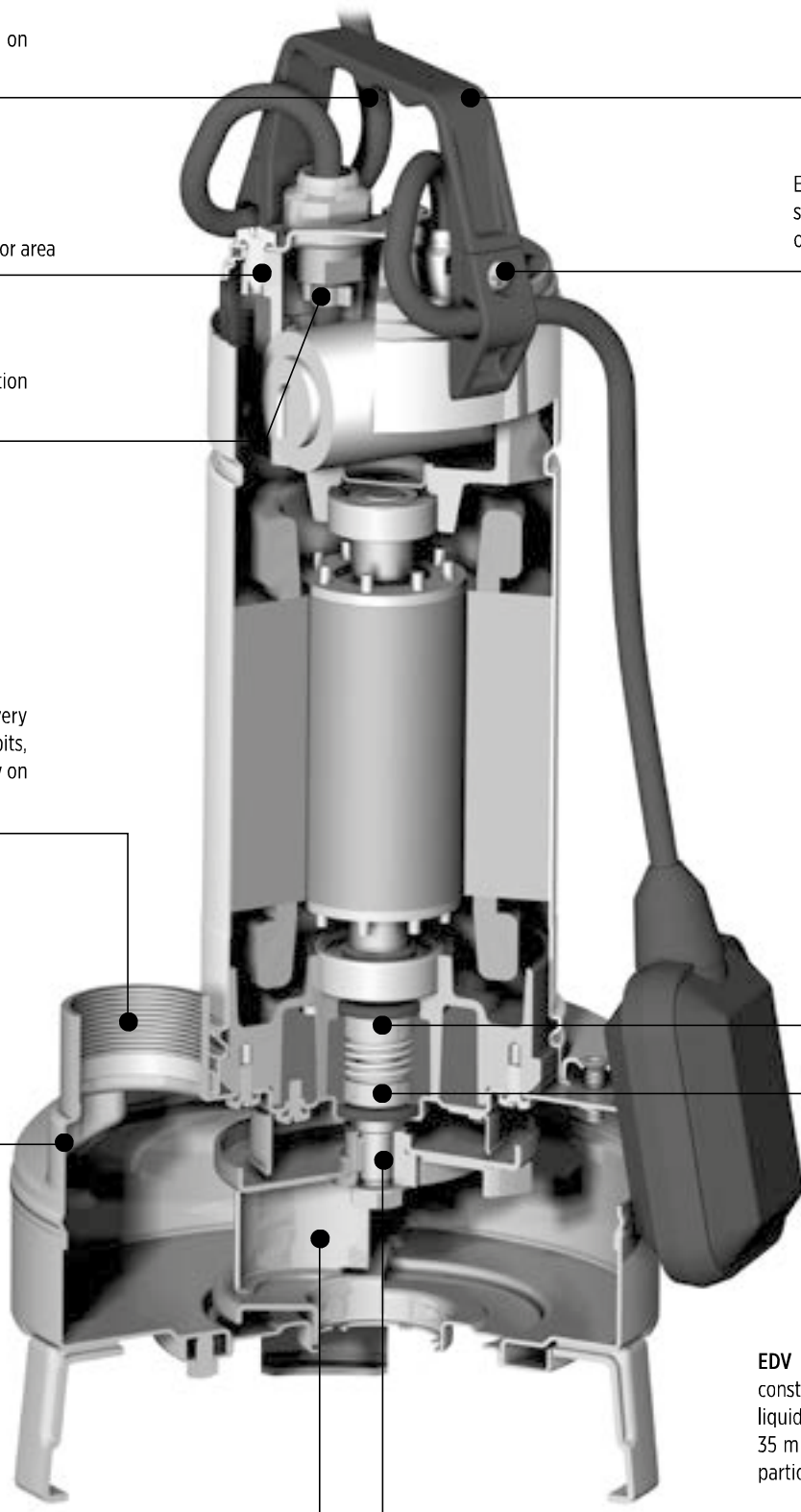

EGN – SUBMERSIBLE DRAINAGE PUMPS FOR CLEAN WATER

CONSTRUCTION

- Single-impeller submersible drainage pump, with open impeller with vertical threaded delivery port (G 1" ½)
- Double mechanical shaft seal with interposed oil chamber, to protect against dry-running

APPLICATIONS

- For clean water containing solids up to 10 mm grain size
- For draining rooms or emptying tanks
- Extraction of water from ponds, streams or pits and for rainwater recovery

OPERATING CONDITIONS

- Liquid temperature up to 35 °C
- Maximum immersion depth: 5 m
- Minimum immersion depth: 205 mm
- Continuous duty (with submerged motor)

MOTOR SPECIFICATION

- 2-pole induction motor, 50 Hz (n ≈ 2900 rpm)
- **EGN:** Single-phase 230 V ± 10%, with float switch and thermal protector
Incorporated capacitor
Cable: H07Rn-F, 3G1 mm², length 10 m, with plug
Cel-UnaL 47166; 5 m for ED5/EDV5
- **EGNT:** Three-phase 230 V ± 10%; Three-phase 400 V ± 10%
Cable: H07Rn-F, 4G1 mm², length 10 m, without plug
- Insulation class F
- Protection IPX8 (for continuous immersion)
- Triple impregnation humidity-proof dry winding
- Constructed in accordance with: EN 60034-1; EN 60335-1, EN 60335-2-41

AVAILABLE ON REQUEST

- Other voltages
- Frequency 60 Hz
- Other mechanical seal
- Cable length 20 m
- Vertical magnetic float switch
- Motor suitable for operation with frequency converter
- Three-phase pumps with incorporated float switch

PUMP IDENTIFICATION CODE

EGN 7 T 400 50 F

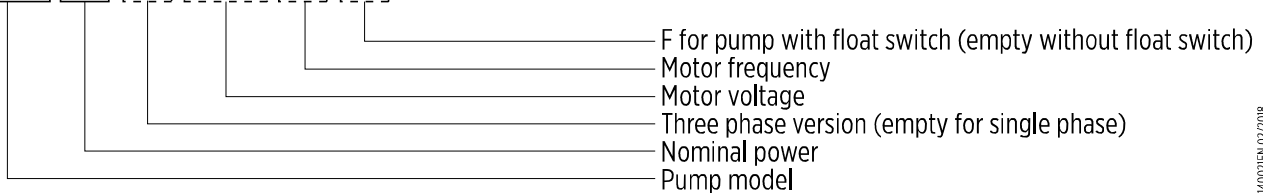

0046031EN 02/2018

EGN

MATERIALS TABLE

Components	Materials
Pump casing / Impeller	Cast iron GJL 200 EN 1561
Motor jacket / Jacket cover / Casing cover	Chrome-nickel steel 1.4301 EN 10088 (AISI 304)
Handle	Polypropylene (with frame in AISI 304)
Shaft	Chrome-nickel steel 1.4301 EN 10088 (AISI 304)
Mechanical seal upper / Mechanical seal lower	Ceramic alumina / Carbon / NBR
Seal lubrication oil	Oil for food/pharmaceutical machinery

DIMENSIONS AND WEIGHTS

Pump model	Dimensions [mm]			Weight [kg]	
	H	h max	h min	1 -	3 -
EGN4(T)	390	410	205	15	14
EGN5(T)	405	425	220	15,5	14,5
EGN7(T)	405	425	220	15,5	14,5
EGN9(T)	430	450	245	18	16
EGN11(T)	450	470	265	19	17,5
EGN15T	450	470	265	-	19
EGN15	480	500	295	20,5	-

DIMENSIONS DRAWINGS

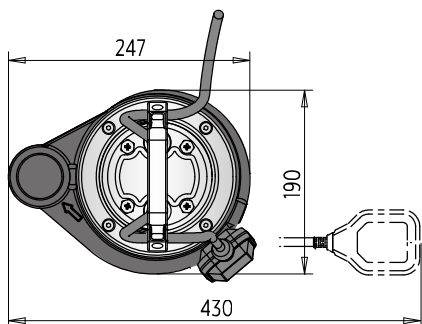
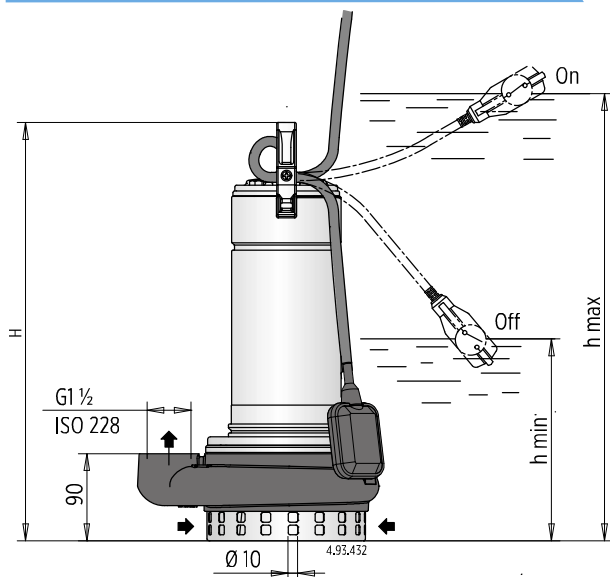

INSTALLATION

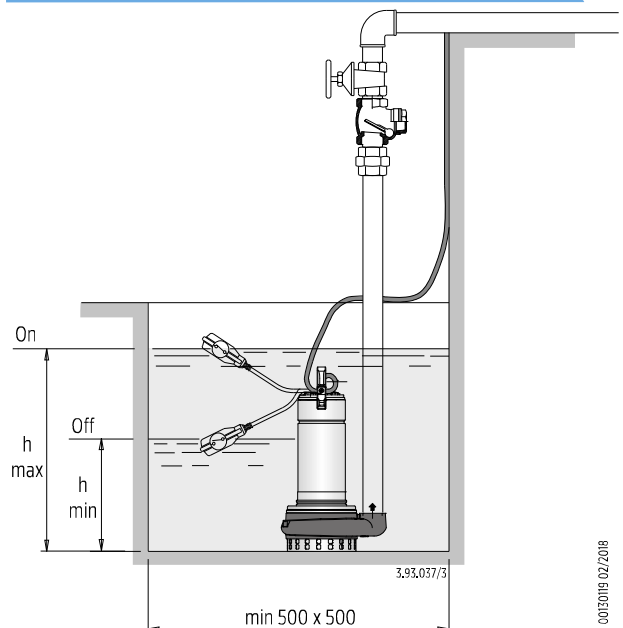

00130119 02/2018

EGN

TABLE OF HYDRAULIC PERFORMANCE $n \approx 2900$ 1/min

Pump model	1x230 V			Capacitor		P ₂		Q = DELIVERY									
	[A]	[µf]	[Vc]	[kW]	[HP]	l/min	50	100	150	200	250	300	350	400	450	500	
						0	3	6	9	12	15	18	21	24	30	30	
H = TOTAL HEAD METERS COLUMN OF WATER [m]																	
EGN 4	3.1	12.5	450	0.45	0.6	10	9.5	8.8	8	6.7	5	3	-	-	-	-	
EGN 5	3.6	16	450	0.55	0.75	12	11.6	11	10.2	9	7.5	5.5	3.2	-	-	-	
EGN 7	4.6	16	450	0.75	1	14	13.5	12.8	12	10.8	9.3	7.5	5.5	3	-	-	
EGN 9	6	25	450	0.9	1.2	16	15.5	15	14.2	13.2	11.8	10.2	8	5.5	2.3	-	
EGN 11	8	30	450	1.1	1.5	18	17.5	17	16.2	15	13.7	11.8	9	7	4.3	1.5	
EGN 15	12	35	450	1.5	2	20	19.5	18.8	18	16.8	15.2	13.2	10.8	8.4	5.7	3	

Pump model	3x230 V		3x400 V		P ₂		Q = DELIVERY									
	[A]	[A]	[kW]	[HP]	l/min	50	100	150	200	250	300	350	400	450	500	
					0	3	6	9	12	15	18	21	24	30	30	
H = TOTAL HEAD METERS COLUMN OF WATER [m]																
EGN 4 T	2	1.2	0.45	0.6	10	9.5	8.8	8	6.7	5	3	-	-	-	-	-
EGN 5 T	2.4	1.4	0.55	0.75	12	11.6	11	10.2	9	7.5	5.5	3.2	-	-	-	-
EGN 7 T	2.8	1.6	0.75	1	14	13.5	12.8	12	10.8	9.3	7.5	5.5	3	-	-	-
EGN 9 T	4	2.3	0.9	1.2	16	15.5	15	14.2	13.2	11.8	10.2	8	5.5	2.3	-	-
EGN 11 T	4.8	2.8	1.1	1.5	18	17.5	17	16.2	15	13.7	11.8	9	7	4.3	1.5	-
EGN 15 T	6.6	3.8	1.5	2	20	19.5	18.8	18	16.8	15.2	13.2	10.8	8.4	5.7	3	-

P₁: Max absorbed power

P₂: Motor nominal power

Density $\rho = 1000$ Kg/m³

Viscosity kinematic $\nu = \max 20$ mm²/sec

PERFORMANCE CURVES $n \approx 2900$ rpm

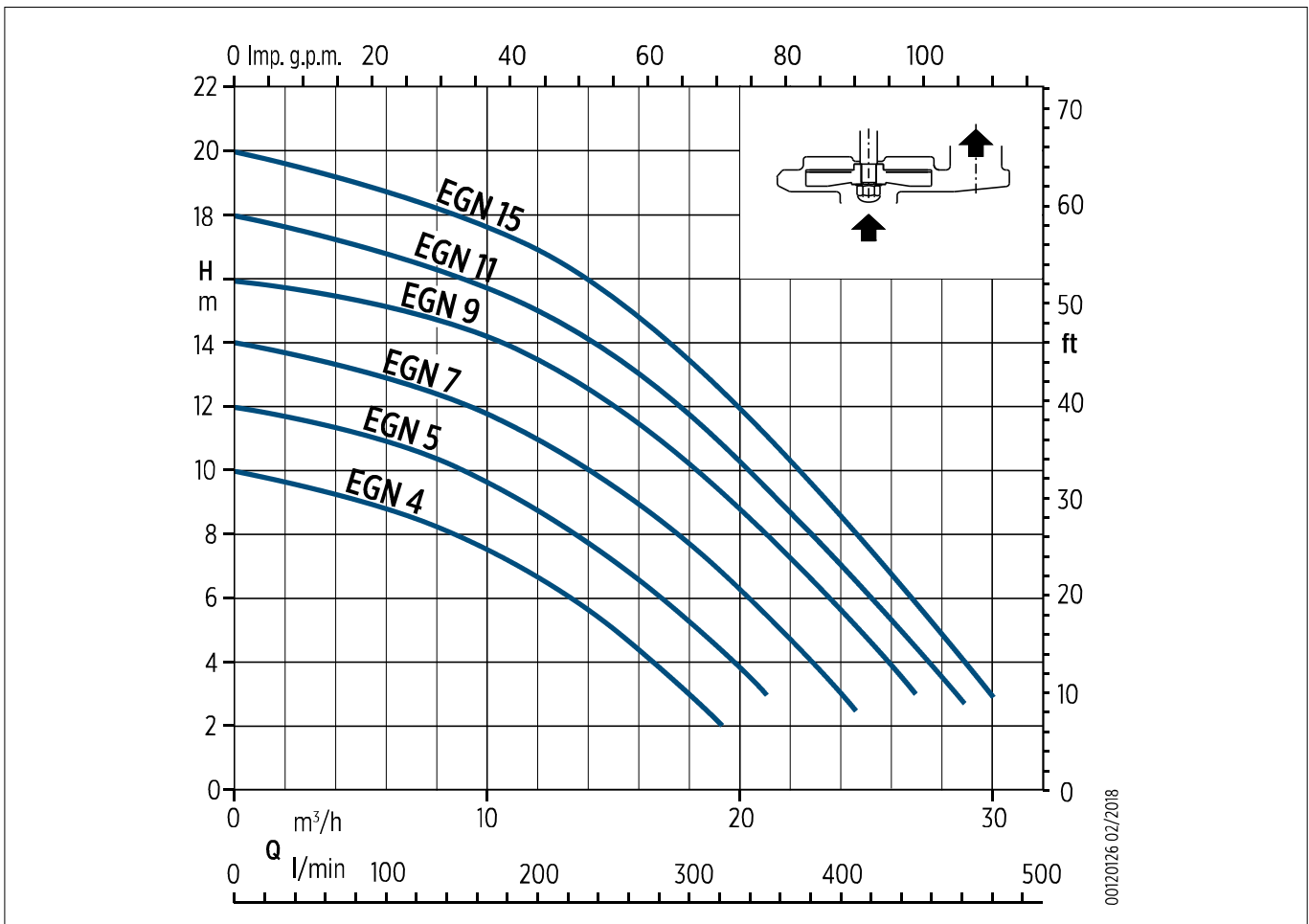

00120126 02/2018

EGN - FEATURES

Cable length 10 m,
pump single-phase with plug

Handle in polypropylene, with
frame in stainless steel

Easy inspection of the capacitor area

Easy adjustment of the float switch:
to allow the adjustment of start/stop
pump levels

Ring against accidental extraction of
the cable

Relief valve: the pump is fitted to a relief
valve for air release around the impeller
granting a proper pump priming also after
long standstill periods

The double shaft seal with oil
chamber separates the motor
from the water and provides
further protection against
accidental operation when dry

G 1 ½ vertical, upward
delivery port for installation
in small pits, without the
need for an elbow on the
pump

Pump casing with epoxy
cataphoresis treatment
joined to the external
paint for a greater
protection against the
corrosion

Chamber with
food/ pharma-ceutical
machinery oil

Shaft in chrome-nickel
stainless steel

Impeller with epoxy
cataphoresis treatment for
a greater protection against
the corrosion.

Suction strainer with a double
row of holes, for extra safety
against clogging: it allows the
passage of solids up to 10 mm

EGT/EGF – SUBMERSIBLE DRAINAGE PUMP FOR DIRTY WATER

CONSTRUCTION

- Single-impeller submersible pumps, with free-flow (vortex) impeller
- **EGT:** with vertical threaded delivery port (G 2")
- **EGF:** with horizontal flanged and threaded delivery port (DN 50 - G 2")
- Double mechanical shaft seal with interposed oil chamber, to protect against dry-running

APPLICATIONS

- For domestic or industrial waste water, dirty water with solids up to 50 mm grain size, for liquids which are compatible with the pump materials
- For draining rooms or emptying tanks
- Extraction of water from ponds, streams or pits and for rainwater recovery

OPERATING CONDITIONS

- Liquid temperature up to 35 °C
- pH value: 6-11
- Maximum immersion depth: 5 m
- Minimum immersion depth: 275 mm
- Continuous duty (with submerged motor)

MOTOR SPECIFICATION

- 2-pole induction motor, 50 Hz ($n \approx 2900$ rpm)
- **EGF/EGT:** Single-phase 230 V \pm 10%, with float switch and thermal protector
Incorporated capacitor
Cable: H07Rn-F, 3G1 mm², length 10 m, with plug Cel-Unel 47166
- **EGFT/EGTT:** Three-phase 230 V \pm 10%; Three-phase 400 V \pm 10%
Cable: H07Rn-F, 4G1 mm², length 10 m, without plug
- Insulation class F
- Protection IPX8 (for continuous immersion)
- Triple impregnation humidity-proof dry winding
- Constructed in accordance with: EN 60034-1; EN 60335-1, EN 60335-2-41

AVAILABLE ON REQUEST

- Other voltages
- Frequency 60 Hz
- Other mechanical seal
- Cable length 20 m
- Motor suitable for operation with frequency converter
- Three-phase pumps with incorporated float switch

PUMP IDENTIFICATION CODE

EGT 7 T 400 50 F

F for pump with float switch (empty without float switch)
 Motor frequency
 Motor voltage
 Three phase version (empty for single phase)
 Nominal power
 Pump model
 (EGT: with vertical threaded delivery port G 2")
 (EGF: with horizontal flanged and threaded delivery port G 2" - DN50)

001400Z/EN 02/2018

EGT/EGF

MATERIALS TABLE

Components	Materials
Pump casing / Impeller	Cast iron GJL 200 EN 1561
Strainer / Motor jacket / Jacket cover / Casing cover	Chrome-nickel steel 1.4301 EN 10088 (AISI 304)
Handle	Polypropylene (with frame in AISI 304)
Shaft	Chrome-nickel steel 1.4301 EN 10088 (AISI 304)
Mechanical seal upper / Mechanical seal lower	Ceramic alumina / Carbon / NBR
Seal lubrication oil	Oil for food/pharmaceutical machinery

DIMENSIONS AND WEIGHTS

Pump model	EGT			Weight [kg]	
	Dimensions [mm]			1 -	3 -
	H	h max	h min		
EGT 5 (T)	460	535	275	15,8	14,8
EGT 7 (T)	460	535	275	16	15
EGT 9 (T)	485	560	300	17,8	15,8
EGT 11 (T)	505	580	320	20,3	18,8
EGT 15 T	505	580	320	-	20,3
EGT 15	535	610	350	21,8	-

Pump model	EGF			Weight [kg]	
	Dimensions [mm]			1 -	3 -
	H	h max	h min		
EGF 5 (T)	460	535	275	16	15
EGF 7 (T)	460	535	275	16,2	15,2
EGF 9 (T)	485	560	300	18	16
EGF 11 (T)	505	580	320	20,5	19
EGF 15 T	505	580	320	-	20,5
EGF 15	535	610	350	22	-

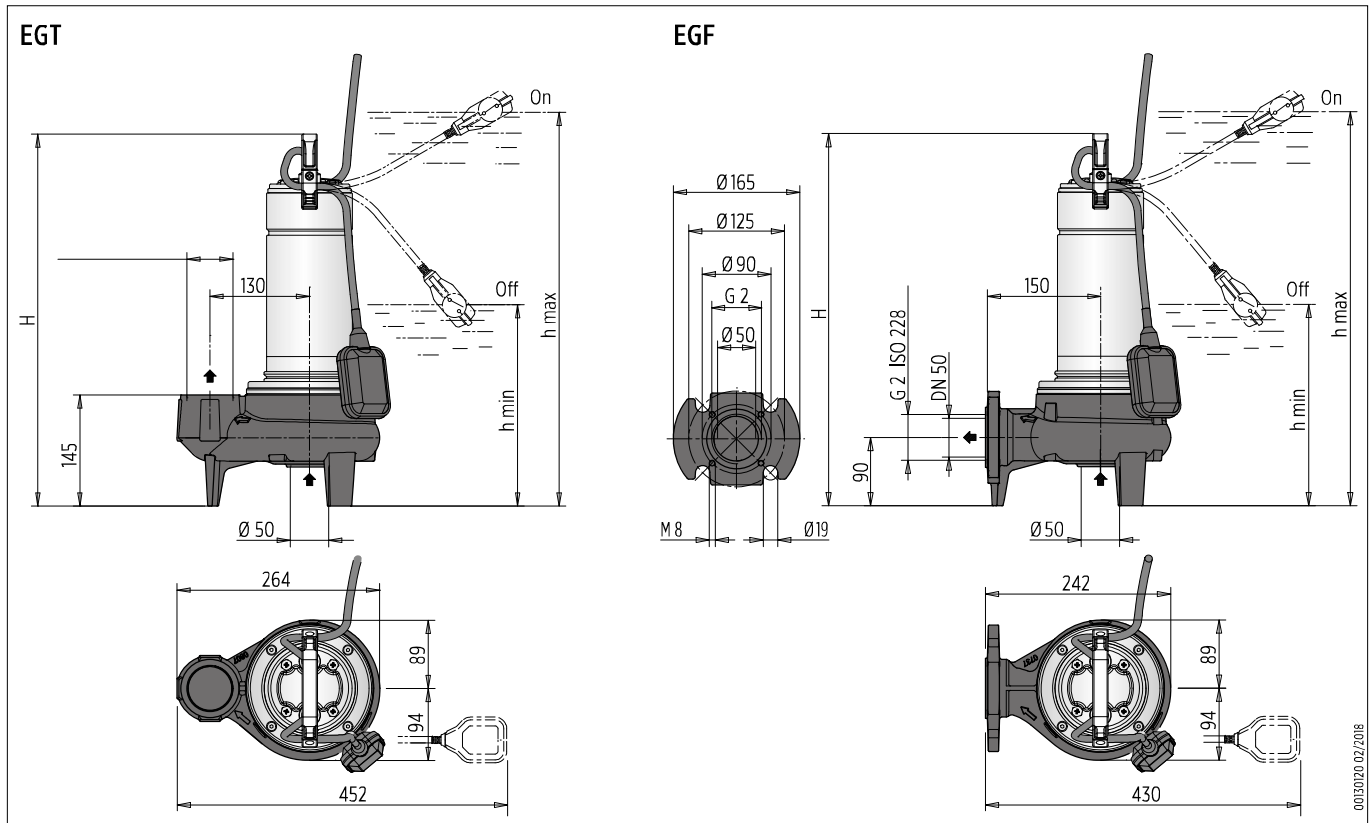

EGT/EGF

TABLE OF HYDRAULIC PERFORMANCE $n \approx 2900$ 1/min

Pump model	1x230 V			Capacitor		P ₂		Q = DELIVERY									
	[A]	[µf]	[Vc]	[kW]	[HP]	l/min 0	50	100	150	200	250	300	350	400	500	550	600
						m ³ /h 0	3	6	9	12	15	18	21	24	30	33	36
EGT/F 5	4.3	16	450	0.55	0.75	8	7.4	6.9	6.3	5.6	4.8	4	3	1.8	-	-	-
EGT/F 7	4.8	16	450	0.75	1	9.3	8.8	8.3	7.7	7	6.2	5.3	4.3	3.2	2.2	-	-
EGT/F 9	6.6	25	450	0.9	1.2	11	10.5	10	9.3	8.6	7.8	7	6.2	5.2	4.2	1.8	-
EGT/F 11	8.4	30	450	1.1	1.5	12.8	12.2	11.6	11	10.3	9.5	8.6	7.7	6.7	5.7	3.3	2
EGT/F 15	12	35	450	1.5	2	15	14.4	13.7	13	12.2	11.3	10.4	9.5	8.5	7.4	4.5	3.5

Pump model	3x230 V		3x400 V		P ₂		Q = DELIVERY									
	[A]	[A]	[kW]	[HP]	l/min 0	50	100	150	200	250	300	350	400	500	550	600
					m ³ /h 0	3	6	9	12	15	18	21	24	30	33	36
EGT/F 5 T	2.6	1.5	0.55	0.75	8	7.4	6.9	6.3	5.6	4.8	4	3	1.8	-	-	-
EGT/F 7 T	3.1	1.8	0.75	1	9.3	8.8	8.3	7.7	7	6.2	5.3	4.3	3.2	2.2	-	-
EGT/F 9 T	4	2.3	0.9	1.2	11	10.5	10	9.3	8.6	7.8	7	6.2	5.2	4.2	1.8	-
EGT/F 11 T	5.2	3	1.1	1.5	12.8	12.2	11.6	11	10.3	9.5	8.6	7.7	6.7	5.7	3.3	2
EGT/F 15 T	6.9	4	1.5	2	15	14.4	13.7	13	12.2	11.3	10.4	9.5	8.5	7.4	4.5	3.5

P₁: Max absorbed power

P₂: Motor nominal power

Density $\rho = 1000$ Kg/m³

Viscosity kinematic $\nu = \max 20$ mm²/sec

PERFORMANCE CURVES $n \approx 2900$ rpm

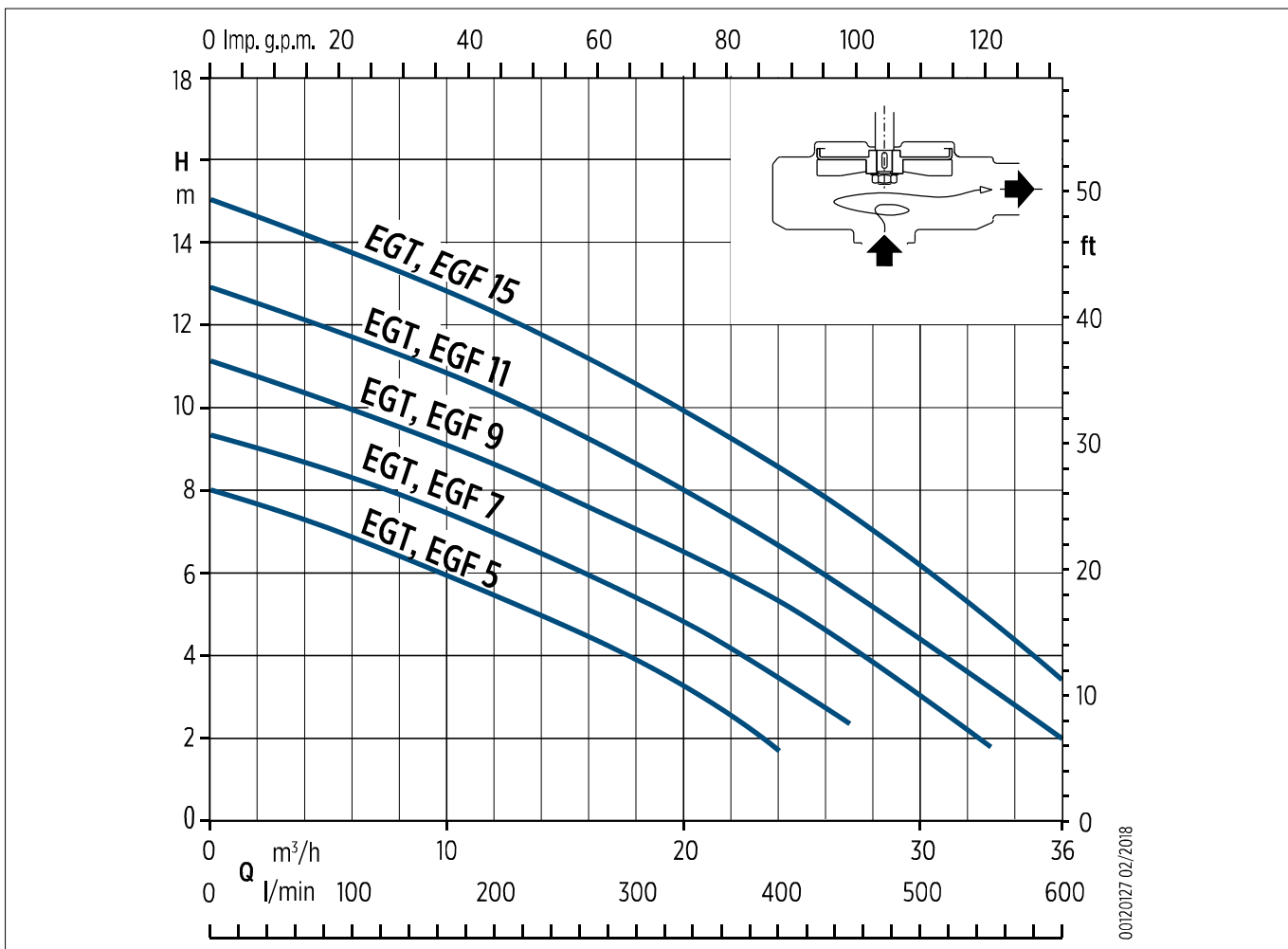

00120127 02/2018

EGT/EGF - INSTALLATION EXAMPLES AND DIMENSIONS

INSTALLATION

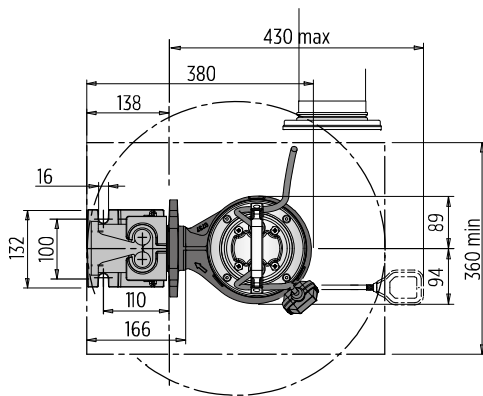
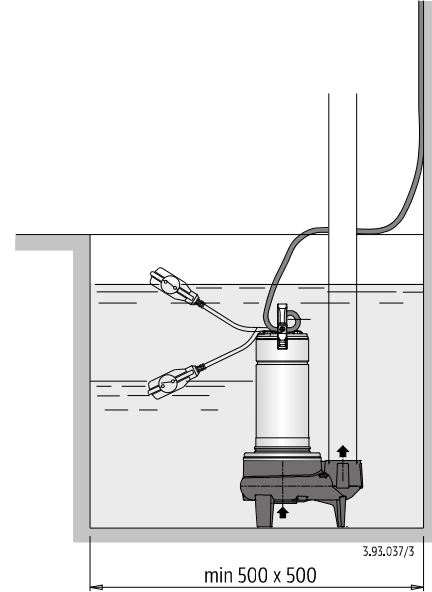
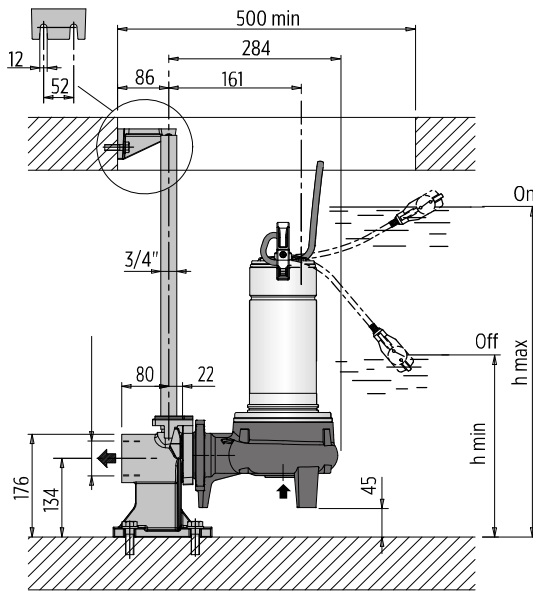

0013021 02/2018

Pump model	EGT		Pump model	EGF	
	Dimensions [mm]			Dimensions [mm]	
	h max	h min		h max	h min
EGT 5 (T)	535	275	EGF 5 (T)	535	275
EGT 7 (T)	535	275	EGF 7 (T)	535	275
EGT 9 (T)	560	300	EGF 9 (T)	560	300
EGT 11 (T)	580	320	EGF 11 (T)	580	320
EGT 15 T	580	320	EGF 15 T	580	320
EGT 15	610	350	EGF 15	610	350

CONNECTION EXAMPLES

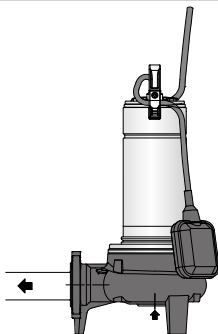

Pump with threaded ports:
pipes screwed into the ports

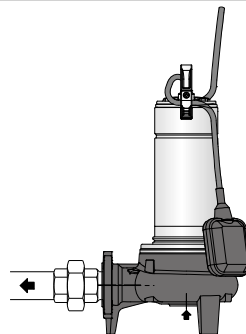

Pump with threaded ports:
pipes with union couplings (locally available)

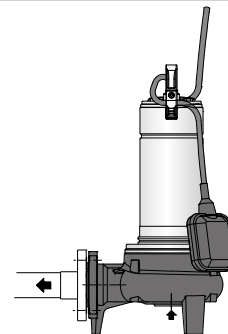

Pump with DN 50 flanged ports:
pipes with counter-flanges

0013021ZEN 02/2018

EGT/EGF - FEATURES

Cable length 10 m,
pump single-phase with plug

Handle in polypropylene,
with frame in stainless steel

Easy inspection of the capacitor area

Easy adjustment of the float switch:
to allow the adjustment of
start/ stop pump levels

Ring against accidental extraction
of the cable

The double shaft seal with oil
chamber separates the motor
from the water and provides
further protection against
accidental operation when dry

Relief valve: the pump is fitted to a relief
valve for air release around the impeller
granting a proper pump priming also after
long standstill periods

Chamber with
food/ pharmaceutical
machinery oil

Maximum flexibility of
connection:
- Flange DN 50
PN 10 EN 1092-2
- N. 4 M8 holes on Ø 90
for duck foot coupling SA-G2"
- G 2 ISO 228

Impeller with epoxy
cataphoresis treatment
for a greater protection
against corrosion

Pump casing with epoxy
cataphoresis treatment joined
to the external paint for a
greater protection against the
corrosion

Shaft in chrome- nickel
stainless steel

The free-fow impeller (vortex)
costruction is particulary
suitable for liquids containing
solids up to 50 mm grain size

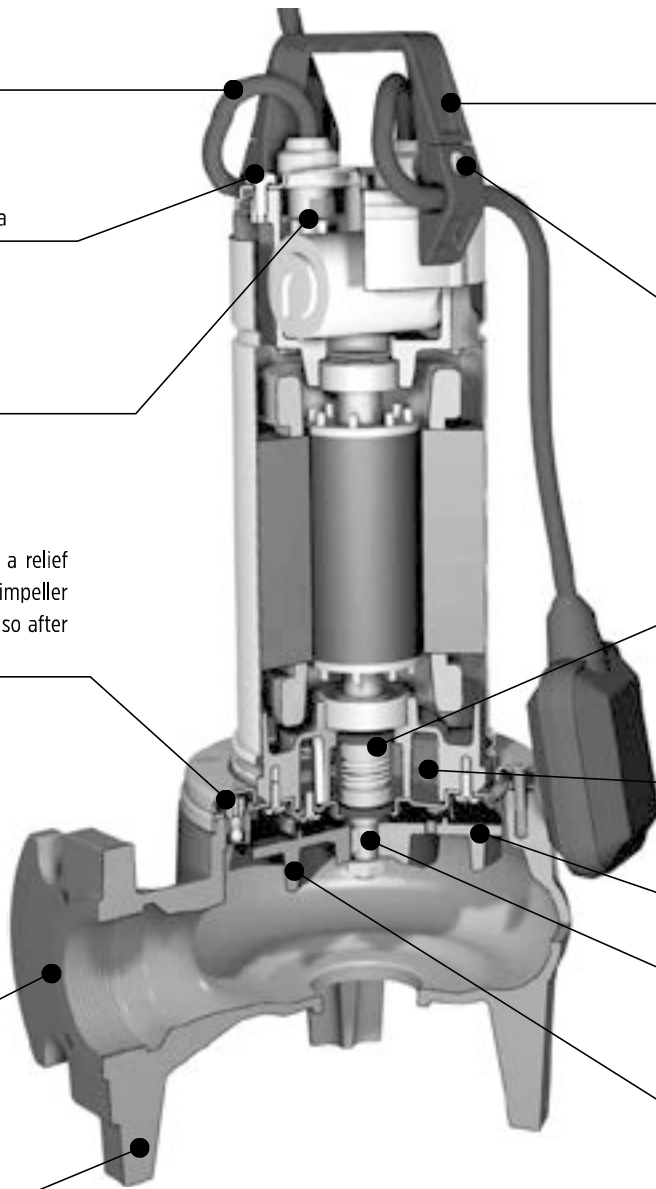

G 2 vertical, upward delivery
port for installation in small
pits, without the need for an
elbow on the pump

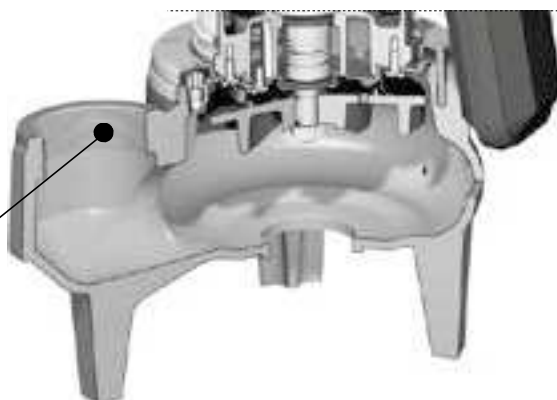

CATALOG REVISION CHANGE NOTICE

Rev. No.	Changes	Page
02	Modified "Motor specification" for EGN pumps	10
	Modified table of "Dimensions installation" for EGT/EGF pumps	17

NOTES

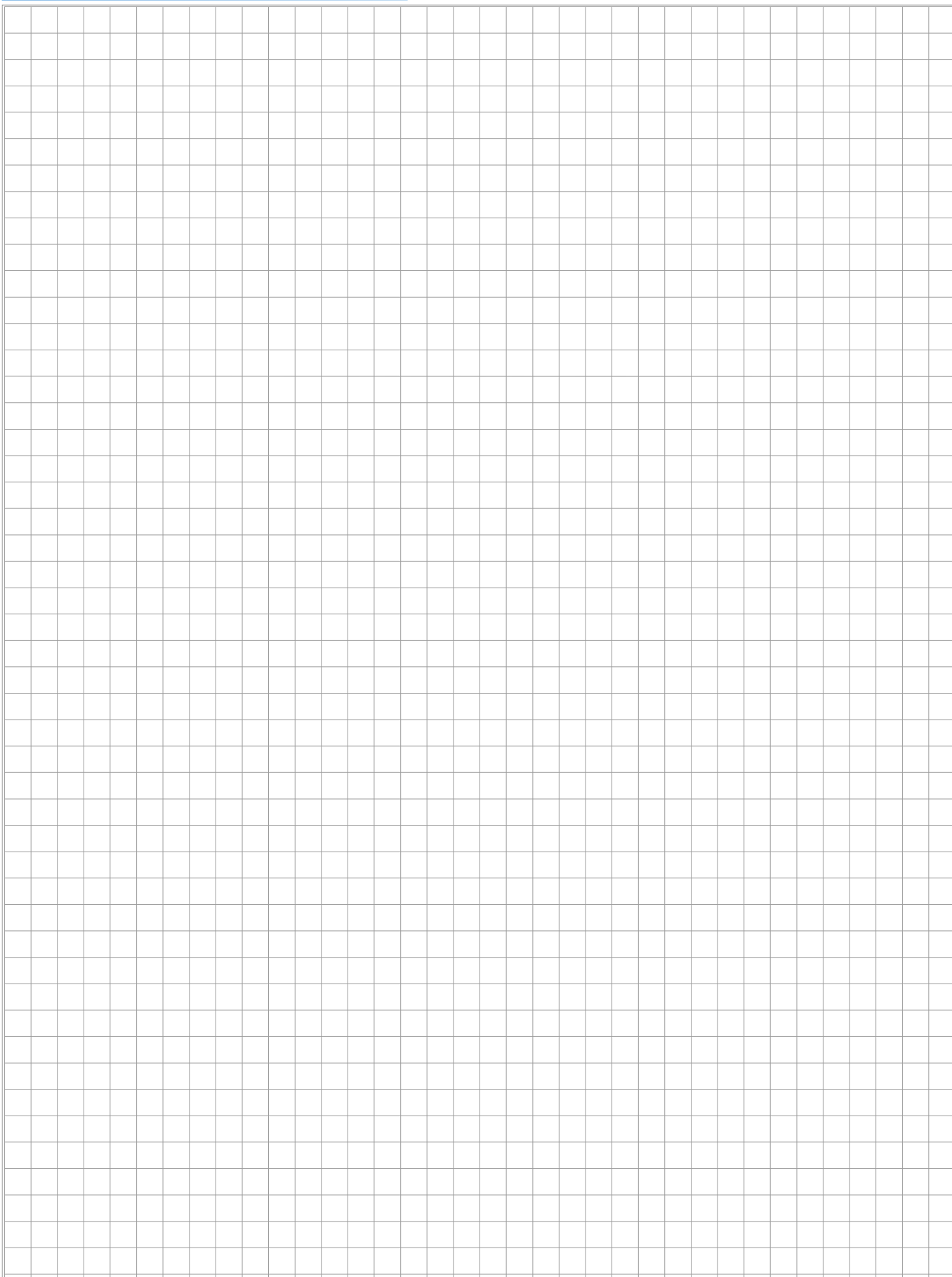

NOTES

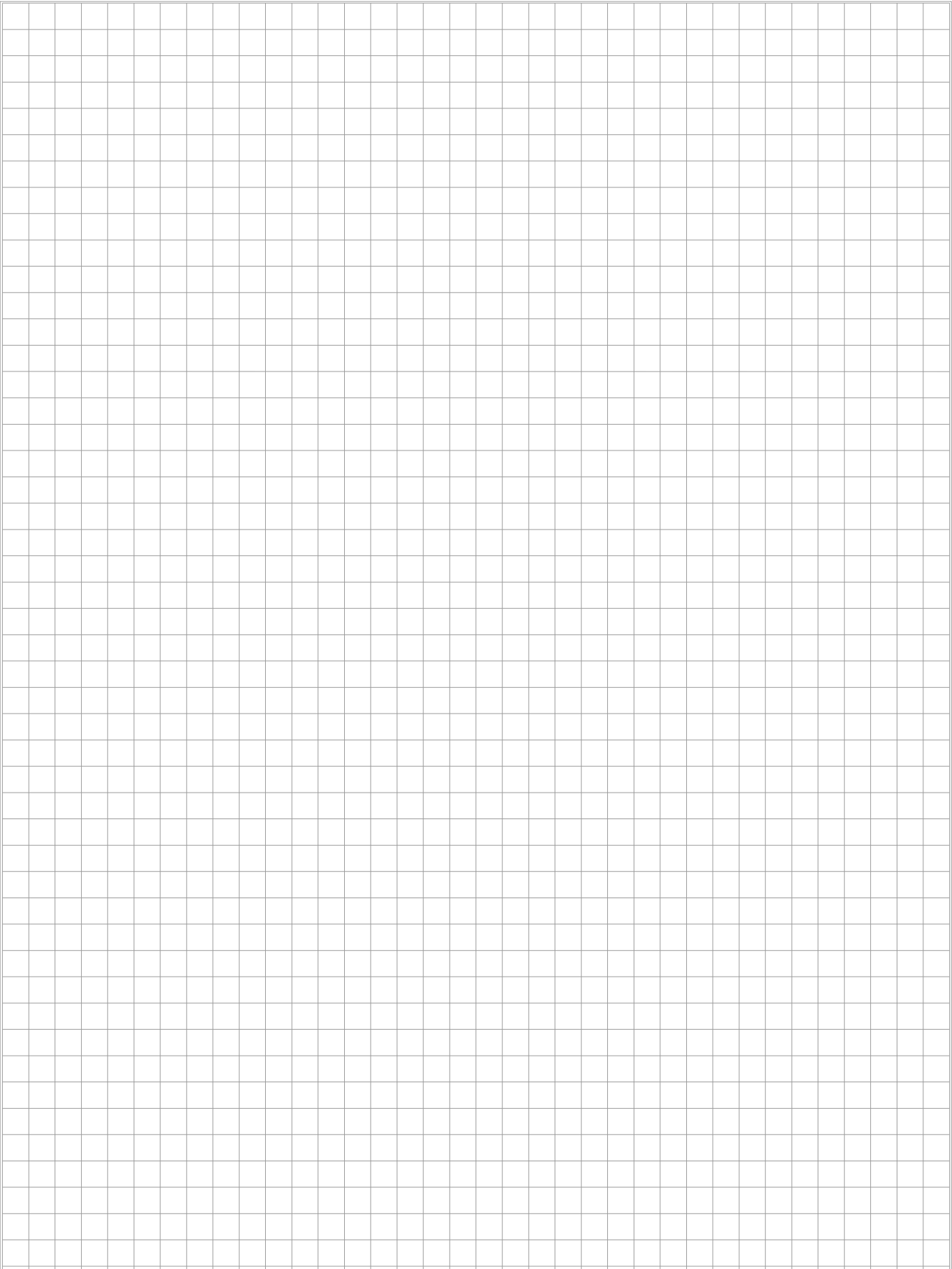

geoquip

WATER SOLUTIONS

Geoquip Water Solutions Ltd.

Unit 7 Sovereign Centre
Farthing Road Industrial Estate
Ipswich, Suffolk
IP1 5AP

Tel: **+44(0)1473 462046**

Email: info@geoquipservices.co.uk

Web: www.geoquipwatersolutions.com



Franklin Electric

Single member - Company subject to the control and coordination of Franklin Electric Co., Inc.

Geoquip Water Solutions reserves the right to amend specification without prior notice